



Prevent Emissions Improve Operations

Particulate Measurement and Control Solutions

Our Edge Is Your Advantage

Auburn FilterSense

Reliable Particulate Monitors

Intelligent Filter Controls

Experienced Support



Particulate filtration systems, such as baghouses and cartridge dust collectors, are critical for industrial productivity and process control.

They are equally important for employee health, plant safety, and compliance with EPA and OSHA regulations.



Prevent

Auburn FilterSense solutions help prevent excess emissions and process problems by providing reliable low-level particulate monitoring, early warning leak detection, better control, and real-time diagnostics of filtration systems. Auburn FilterSense uniquely focuses product technology on proactive and preventive solutions.



Improve

Improvements to operations and a fast return on investment are available through a range of benefits. Auburn FilterSense develops solutions not just to monitor particulate or control filtration processes but to effectively improve plant operations.

Real Solutions



42% of upsets are attributable to insufficient process insight.

"DynaCHARGE™ is like a microscope; we see things we never saw with our opacity monitor. And we don't have to clean it!" - Battery Plant



Emergency maintenance costs 3-4x more than the same preventive task.

"The developing leak was exactly where the B-PAC™ indicated it was; we were shut down for only minutes." - Chemical Plant



80% of plants report a need to be more efficient.

"Our Auburn FilterSense system [B-PACs™ and FilterWARE™ HMI/SCADA] eliminated our manual inspections." - Minerals Plant



US-EPA enforcement totaled \$9.7B in 2014.

"We keep emissions below 1 mg/m³; our flow is nearly 3M CFM! This would not be possible without Auburn FilterSense." - Aluminum Plant

Valuable Benefits

Process Control & Optimization

- Control DP, airflow, production and ventilation
- Analyze performance and diagnose problems
- Optimize filter cake and filtration efficiency
- Minimize compressed air and energy use
- Prevent loss of valuable powders

Engineering & Support

- Assess OEM filter life and performance warranty
- Keep internal resources focused on core operations
- Take advantage of turn-key, proven solutions
- Solve challenges with industry experts

Consider your ROI

Check off your ROI opportunities and feel free to call us today to discuss your application further.

Operating & Maintenance Costs

- Eliminate manual inspections
- Prevent costly unforeseen downtime
- Avoid emission damage (cars, structure, homes)
- Extend filter life and lower replacement costs
- Protect downstream equipment (blowers, vacuum pumps, HEPA's, turbines, oxidizers)

EPA, Health & Safety (OSHA/NFPA)

- Prevent out-of-compliance, avoid fines, shutdowns, and lawsuits
- Reduce personnel exposure to confined spaces, hazardous particulate, and gases
- Ensure hazardous dust pickup, prevent dust accumulation
- Be socially responsible and adhere to corporate environmental ethics and policies such as ISO 14000

Trust and Value

FilterSense Particulate Monitoring Control Solutions

Analyze Optimize Comply

Auburn FilterSense is the #1 choice of experienced end users and OEMs around the world . . .

Engineers and plant personnel that have used alternative products know that there is a difference. They trust Auburn FilterSense product specifications, quality, and performance. They value Auburn FilterSense advanced technology, beneficial product features, expertise for large projects, and proactive support.

Higher value and long-term satisfaction . . .

"Auburn FilterSense [PM 100 PRO] is our main filter analyzer; it outperforms our forward scatter PM CEMS." - Aluminum, Plant Engineer

"With the other leak detectors, we were flying blind on alarm set up, and damaged vacuum pumps." - Fly Ash Conveying, OEM

Proven Results

Visit www.FilterSense.com for application results in your industry.

Auburn FilterSense has thousands of proven installations in virtually every application and industry around the world. While Auburn FilterSense is the leader in fabric filter applications, our particulate monitors are applicable to many cyclone, powder flow, electrostatic precipitator, and mist eliminator applications.



- Metals
- Cement
- Power/Utility
- Incineration
- Foundries
- Smelting



- Chemicals & Plastics
- Pharmaceuticals
- Food & Dairy
- Carbon Black & Toner
- Minerals/Mining
- Tobacco

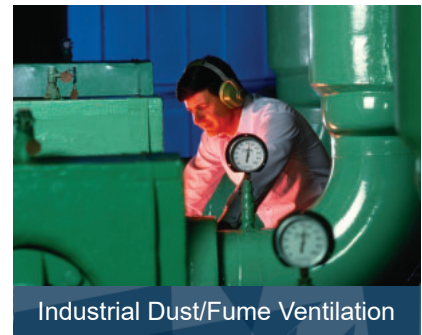

- Automotive Parts
- Lead Battery Assembly
- Welding & Plasma Cutting
- Woodworking
- General Manufacturing
- Metal & Foundry Casting



A Full Range of Products & Services

Product Portfolio

For varying process conditions, regulations and budgets, Auburn FilterSense offers a full range of products. Particulate monitors include **durable low-cost detectors** to **high-performance measuring instruments**. Controls include **basic and diagnostic controls** to **large-scale comprehensive control systems**. Additional products include **SCADA/HMI and EPA reporting** software, differential pressure transmitters, and basic pulse jet timers.

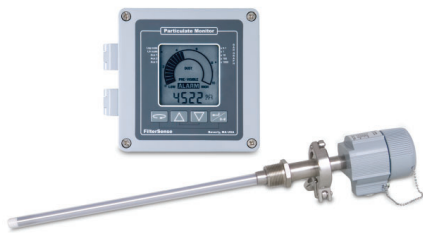

Technical Support

Auburn FilterSense technical support is unmatched in the industry. Whether the topic is application, EPA compliance, installation, or product related, Auburn FilterSense has the expertise. We answer questions and provide consultation quickly and will proactively stay in contact with you until your needs are fully satisfied.

For on-site support, Auburn FilterSense provides short-notice response and scheduled service to customers in all regions.

For added local support, regional industry partners and representatives are reliable and experienced to complement Auburn FilterSense support.

Engineering & Systems Integration

- ▶ Filtration system optimization
- ▶ Stack test correlations and EPA alarm points
- ▶ Operating and maintenance plans for EPA
- ▶ Fieldbus communications integration
- ▶ PLC/DCS and HMI/SCADA integration
- ▶ Control system engineering and manufacturing

Product Design

State-of-the-art electronics and process control device engineering . . .

MICS™ Platform

Auburn FilterSense's MICS™ platform (pronounced "mix") is a Modular Instrumentation and Control System that offers a choice of processing power and display, a wide range of technology and functionality features (such as SD card support), modular I/O, and selection of fieldbus (all major protocols). MICS™ provides easy expansion, reduced spares, and simplified service.

At the core of MICS is a CANbus architecture and slice-style DIN rail modules (no backplane). CANbus provides reliable high speed communications while, mechanically, the modules provide protection of electronics and easy in/easy out installation.

Advanced Processor/Display



Basic Processor/Display



Enclosures



I/O and Sensor Modules

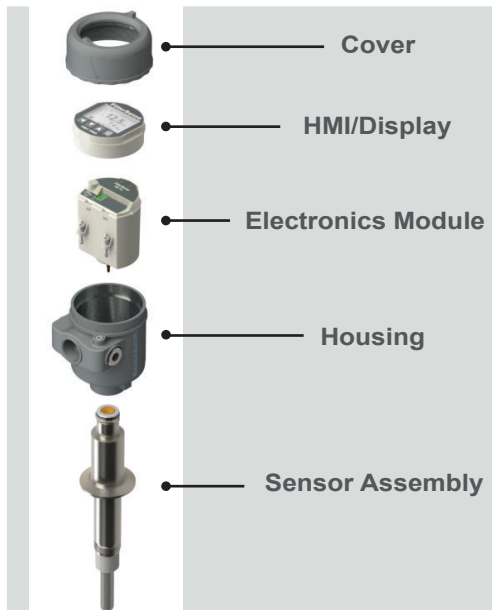

Instrument Platform

Auburn FilterSense's instrument platform provides cutting-edge design and leading value for single point instrumentation (line powered alarm devices and loop powered transmitters - **HART** available).

Industry leading technology includes accurate low level sensing and true automatic zero, and span measurements (for EPA self-tests) under the low power constraints of a loop power device.

Mechanical features include modular display, removable electronics module, water intrusion protection, custom housing (rotatable with multiple conduits), heavy-duty modular sensor, and both integral one-piece instruments (shown) and remote electronics.

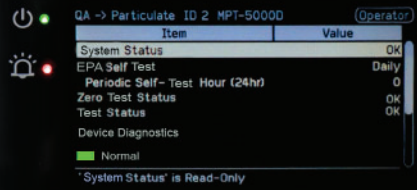

Item	Value
System Status	OK
EPA Self Test	Daily
Periodic Self-Test Hour (24hr)	0
Zero Test Status	OK
Test Status	OK
Device Diagnostics	
Normal	

System Status is Read-Only

PRO Models

Both Auburn FilterSense product platforms offer basic and PRO models. PRO models have value-added technology for demanding optimization and up time requirements of process plants, quality assurance features and accuracy requirements for EPA compliance, heavy-duty construction for long life in harsh conditions, and highest hazardous area ratings. Basic models offer a lower price yet still provide essential functions and high quality.



Advanced Features

Device & Process Diagnostics

Device health diagnostics (to **NAMUR 107**), such as ground and power quality checks, ensure proper installation while process diagnostics such as real-time signal analysis provide service alerts and insight into process occurrences.

EPA QA and Accuracy

Self-test circuits (zero, upscale/span, linearity and sensor condition), and high precision options enable meeting EPA quality assurance, and relative mass accuracy specifications in standards such as, but not limited to, ASTM D7392 and EN 15859.

Internal Data & Event Logging

Logging of process values, alarms, EPA self-tests, and events goes beyond record keeping or data redundancy. It provides added insight for faster decision making and better remote support.

Communications

Certified fieldbus protocols, industrial Ethernet, **HART**, 4-20mA (to **NAMUR 43**), USB, and SD cards provide efficient ways to manage devices, take full advantage of available information, and better control processes.

Heavy-Duty Construction

PRO electronics can operate from -40 °F (-40 °C) to 158 °F (70 °C), and with critical circuits conformal coated, can be installed in dusty and corrosive environments. All PRO sensing probes are engineered to withstand the rigors of 24/7/365 operation in harsh processes while not overlooking less known but critical factors, such as flow-induced vibration fatigue.

Hazardous Areas

PRO remote control units offer built-in intrinsic safety barriers to directly connect PS Series particulate sensors for **intrinsically safe installations** (all classes/zones/groups). PRO loop powered transmitters with integral electronics (i.e., one-piece devices) are also available intrinsically safe.

US-EPA has fined individual plants up to \$2M for baghouse violations.

“We trust that when one of our four Auburn FilterSense emission monitors is in alarm, we need to act.”

- Cement, Environmental Manager



DynaCHARGE™ Particulate Monitors

Continuous particulate flow/emissions monitors, filter leak analyzers, and filter leak detectors employ reliable DynaCHARGE™ induction-sensing technology.

Models:

PM 100 Series

PM 1 Series



DynaCHARGE™ Particulate Monitoring Technology

The #1 Choice of Experienced End Users and OEMs

- ▶ End users choose DynaCHARGE™ to replace competing devices and opacity more than any other brand.
- ▶ OEMs choose DynaCHARGE™ more than any other brand.

As particles flow over a sensing probe, charge is induced into the probe creating small currents in the picoamp (pA) range. The signal is processed into an output proportional to mass.

Auburn FilterSense invented particulate monitoring using charge induction and remains the technology leader.

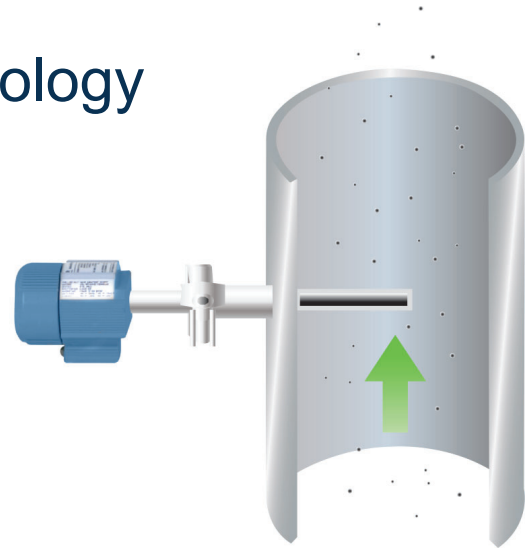

Reliable

Prevent False Alarms

Fully insulated probes prevent false alarms from moisture, corrosives, agglomeration, and most conductive particles – without air purge.

Low Maintenance

Typically maintenance free, where competing charge-sensing, tribo, and optical monitors often have 1–3 month cleaning intervals.

Durable

Sensors are free of electronics on most models (optional on all). Removing electronics from heat and vibration increases performance and product life and enables intrinsic safety approvals.

Stringent Quality

ISO 9001 certified design and manufacturing, accelerated life testing in the design stage (HALT), thermal stress testing prior to shipment, conformal coating circuits, and quality packaging ensure reliability.

Easy to Use

Installation

Fast and easy to install with no special alignment or structural needs (like optical). Remote electronics provide safe, easy commissioning for the many filtration monitoring points that are difficult to access.

Simple Operation

An absolute output proportional to particulate mass provides normalized values for straightforward set up and historical data review. There are also no confusing sensitivity adjustments or blind autosest functions.

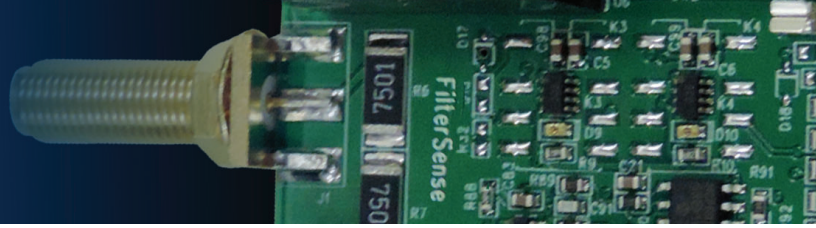

High Precision When You Need It

High-precision options provide superior low-level detection, and increased linearity for mass correlations resulting in exceptional measurement and graphical filter leak analysis.

DynaCHARGE™ vs. Competition (Waste to Energy Plant)

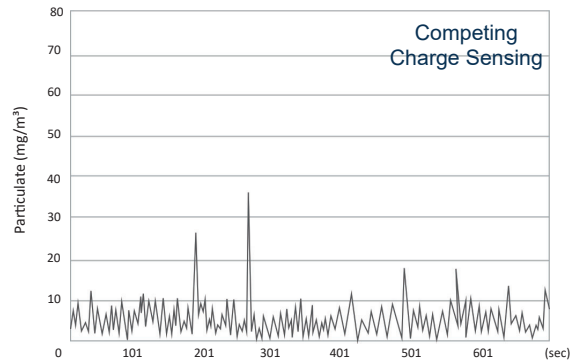
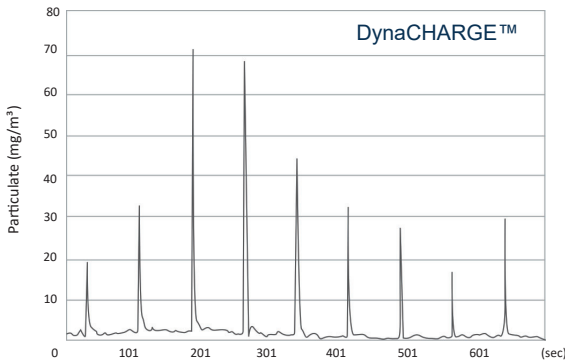

DynaCHARGE™ vs. Optical (Aluminum Plant)

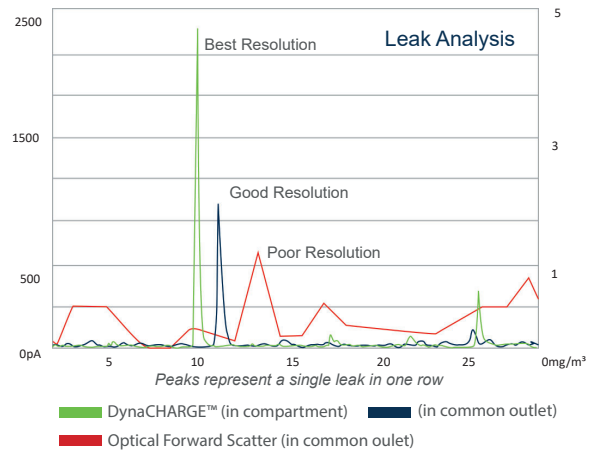
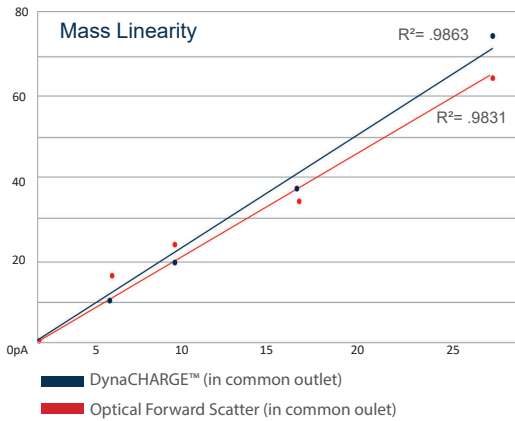

EPA Compliance

DynaCHARGE is applied to EPA MACT, NESHAP, Title V/CAM and corresponding international regulations (TUV, MCERTS etc).

Models are available for all categories of compliance monitoring including:

- Correlated output in mg/m³
- Relative mass monitoring
- Leak analysis/detection (BLDS)

Instrument accuracy, self-testing, and QA functions meet regulatory design and performance standards such as:

- ASTM D7392
- EN 15859

DynaCHARGE™

PM 100 Series

Particulate Monitoring Systems (Single and Multi-Point)



PM 100 PRO

- Top Performance & Heavy-Duty Construction
- Widest Range of Features and Configurations

The PM 100 PRO is the industry leader for critical process control and EPA compliance. It consistently outperforms other top level charge and optical devices. Its advanced processor/display and MICS™ platform offer a total solution.



PM 100

- Essential Features and Functions
- Lower Price with High Quality

The PM 100 provides reliable particulate monitoring and leak/flow detection along with a solid range of basic features, functions, and I/O via the MICS™ platform.

- **DynaCHARGE™ (All Precision, 1-32* points)**
 - Measurement (mg/m³), Monitoring, Detection
- **Device and Process Diagnostics (to NAMUR 107)**
 - Ensure installation and gain time-saving insights
- **Automatic EPA Self-Tests and QA Log**
 - Adhere to regulations, reduce labor and errors
- **Performance and Design to EPA Standards**
 - Exceeds ASTM D7392 and EN 15859
- **Real time, Historical, and Comparative Trending**
 - Quick set up, awareness, and decision making
- **Alarm Management System**
 - Set logic, groups, acknowledgment, security
- **Data Historian**
 - Extensive data and event recording
- **Choice of Certified Fieldbus, SD card**

*Limited by type; consult factory

- **DynaCHARGE™ (Standard Precisions, 1-16* points)**
 - Monitoring, Detection
- **Alarm relays, 4-20mA outputs, Basic Data Log**
- **Choice of Certified Fieldbus, SD card**

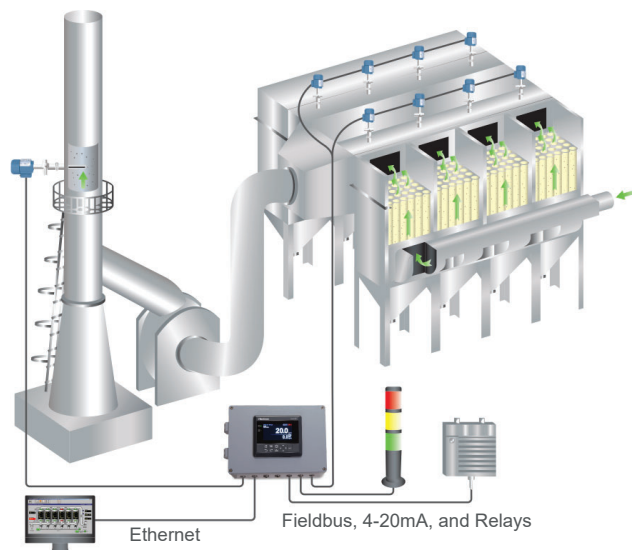

DynaCHARGE™

PM 1 Series

Particulate Monitors (Single-Point/Single Function)



PM 1 PRO

- High Performance and Heavy-Duty Construction
- 2-Wire Loop or Universal Line Power with Relays

The PM 1 PRO is the benchmark for reliability and features in a standard particulate monitor and leak/flow detector. A state-of-the-art instrument, it is the first loop power particulate monitor with EPA certifiable self tests and performance.

- **Device Diagnostics (to NAMUR 107)**
 - Help ensure installation, proper operation
- **Automatic EPA Self-Tests**
 - Adhere to regulations, also for critical process
- **Performance and Design to EPA Standards**
 - Meets ASTM D7392 and EN 15859
- **Communication and Data Logging**
 - HART, USB, and basic internal data logging

Integral or Remote Electronics
(as shown)

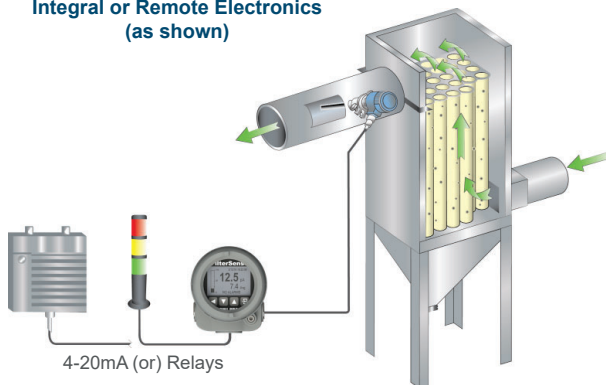

4-20mA (or) Relays



PM 1

- Low Cost and Simple
- 2-Wire Loop or Universal Line Power with Relays

The PM 1 is the industry's best value in a basic particulate monitor and leak/flow detector. The engineering and quality greatly exceed comparably priced devices. Low cost justifies monitoring even small nuisance dust collectors.

- **DynaCHARGE Technology**
 - Superior reliability over other charge and tribo
- **Digital Readout, Lockable Keypad**
 - Simple text prompts (no trim pots or blind auto set)
- **Convenient Loop Check and Alarm Functions**
 - Speeds up and confirms installation

Integral Electronics Only

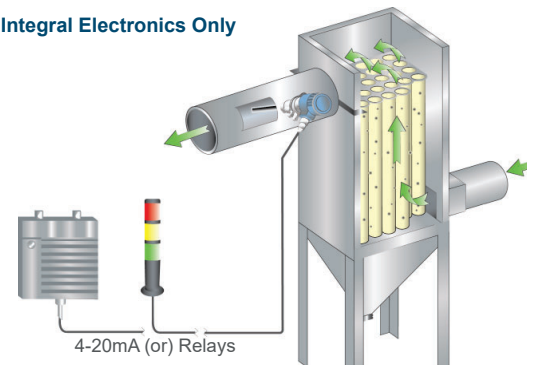

4-20mA (or) Relays

DynaCHARGE™

Model Comparison



Key Features ¹	PM 100 PRO	PM 100	PM 1 PRO	PM 1
Functions/# of Monitoring Points	Multi-Function/Multi-Point		Single-Function/Single-Point	
Number of Points (limited by type)	1 to 32 ²	1 to 16 ²	1	1
Modular Expandable System (MICS™)	✓	✓		
Resolution/Minimum Detection	<1 mg/m ³	~1-5 mg/m ³	1 mg/m ³	~1-5 mg/mg ³
Device Health Diagnostics	●		◐	
Meets EPA Performance Standards	✓		✓	
Data Logging	●	○	○	
On Screen Trending	✓			
Communications	Fieldbus ³	Fieldbus ³	HART	
Alarm Capabilities	●	◐	○	○
Auxiliary Inputs (pressure, temp, flow, etc.)	✓			
Advanced Functions (process run input, realtime & avg outputs, calculated values)	✓			

Application				
Measure (mg/m ³) - Process/EPA	●		◐	
Monitor - Process/EPA	●	◐	●	○
Detect - Maintenance	●	●	●	●
Large Stack	●		◐	
Multi-Compartment Baghouse	●	◐	◐	○
Single-Compartment Process Baghouse	●	○	◐	○
Nuisance Dust Collector	●	●	●	●
Process Flow/Injection Lines/Cyclones	●	○	◐	○
Other; Mist Eliminator/ESP	●		◐	

General Technical				
Power Supply	100-240 VAC (or) 24 VDC	100-240 VAC (or) 24 VDC	2-wire loop or universal line	2-wire loop or universal line
Processor/Display	Advanced/Color Graphic	Basic/Graphic	Advanced/Graphic	Basic LCD
Discrete Output	Up to 16	Up to 8	Up to 2	Up to 2
Analog Output	Up to 16	Up to 8	Up to 1	Up to 1
Analog & Discrete Inputs	Up to 16 each	Up to 4 each	None	None
Ambient Temperature	-40 °F to 158 °F (-40 °C to 70 °C)	-13 °F to 140 °F (-25 °C to 60 °C)	-40 °F to 158 °F (-40 °C to 70 °C)	-13 °F to 140 °F (-25 °C to 60 °C)
Particulate Sensor Type	PS 10-HP or XD	PS 10-S	PS 10-HP or XD	PS 10-S
Process Temperature (sensor)	-40 °F to 1650 °F (-40 °C to 898 °C)	-13 °F to 450 °F (-25 °C to 232 °C)	-40 °F to 1650 °F (-40 °C to 898 °C)	-13 °F to 450 °F (-25 °C to 232 °C)
Process Pressure (sensor)	1,000 PSI (69 bar)	10 PSI (0.69 bar)	1,000 PSI (69 bar)	10 PSI (0.69 bar)
Enclosure Rating (explosion proof available)	NEMA 4X/IP66	NEMA 4/IP65	NEMA 4X/IP66	NEMA 4/IP65
Hazardous Area Rating	Class I Div. I (Zone 0/20)	Class II Div. II (Zone 22)	Class I Div. I (Zone 0/20)	Class II Div. II (Zone 22)

Note ³: Certified Fieldbus: EtherNet/IP, Modbus (TCP, RTU), PROFINET IO, PROFIBUS (DPV1, VO), DeviceNet, ControlNet, CanOpen, EtherCAT

Note ²: Limited by type Note ¹: Features may be optional

● = Best ◐ = Good ○ = Basic

Particulate Sensors

PS Series



Auburn FilterSense PS Series particulate sensors are unique, robust, passive sensors that connect to DynaCHARGE™ and B-PAC™ control units. These sensors are free of electronics. Heat and vibration do not reduce accuracy or life of the sensor. They enable intrinsic safety for line powered control units and make for more accessible installations since many filtration monitoring points are difficult to access. The PS 10-HP has proven to be the most reliable and durable sensor available.



Basic

High Performance

Extreme Duty

Key Features	PS 10 - S	PS10 - HP	PS 10 - XD
Fully-Insulated/Isolated Probe	Coating	Layer	Layer
Heavy Duty Construction		✓	✓
Modular Design		✓	
Rotatable Housing		✓	✓
Field Serviceable parts		✓	
Application			
Aggressive/Corrosive Media		●	●
Moist/Conductive Media	◐	●	◐
General Technical			
Process Connection	NPT, Quick Clamp	NPT, Quick Clamp, Flange	Flange
Wetted Materials	316 L Teflon -	316 L Hastelloy C Teflon	316 L Hastelloy C Teflon
Max. Process Temperature	450 °F (232 °C)	500 °F (260 °C)	1650 °F (898 °C)
Max. Process Pressure	10 PSI (0.69 bar)	100 PSI (6.9 bar)	1000 PSI (69 bar)
Max. Probe Length	36 in (914 mm)	72 in (1828 mm)	36 in (914 mm)
Enclosure Rating (explosion proof available)	NEMA 4X/IP66	NEMA 4X/IP66	NEMA 4X/IP66
Hazardous Area Rating	Class II Div. II (Zone 22)	Class I Div. I (Zone 0/22)	Class I Div. I (Zone 0/22)

● = Best ◐ = Good ○ = Basic

Emergency maintenance costs 3-4x more than the same preventive task.

“Prior to installing B-PACs we had 9 unplanned shut downs. We’ve had zero emergency outages since.”

- Chemical, Reliability Engineer



B-PAC™ Controls Baghouse Performance Analysis & Control

Control and monitoring systems for all types of baghouses and cartridge dust collectors provide optimized filtration and highly beneficial preventive diagnostics.

Models:

B-PAC™ G3 PRO

B-PAC™ G3



Baghouse Performance Analysis & Control

Typical 1–2 year ROI

Auburn FilterSense pioneered intelligent filter cleaning and diagnostics and is the industry leader. B-PACs™ ensure filters run smoothly with the proper differential pressure (DP) and low emissions.

B-PACs™ reduce energy use and lower costs by providing equipment condition monitoring and actionable diagnostics that reduce maintenance rounds, automate regulatory O&M inspection requirements, and prevent unforeseen downtime. They enable assessing OEM filter life and performance warranties. The initial capital expense of baghouses and dust collection systems is far lower than its long-term total cost of ownership (TCO). B-PACs™ significantly reduce TCO.

For pulse-jet filters B-PACs™ integrate cleaning control (control of solenoids and diaphragms) with measurement and analysis of differential pressure, particulate, header pressure, pulse counts, and running hours. Airflow, fan amps, temperature, level, and other inputs and control functions (dampers, VFDs, airlocks, etc.) can be added for further enhancements.

IntelliPULSE™ Intelligent DP Control

- ▶ Maintain differential pressure within 0.1 InWC with minimum pulsing
- ▶ Lower emissions and extend filter life with less pulsing
- ▶ Ensure consistent airflow to maintain production, ventilation, and dust recovery
- ▶ Reduce compressed air use by 15–40% over standard on-demand cleaning, and up to 90% over continuous cleaning



In addition to IntelliPULSE™ DP/cleaning control and diagnostics, B-PACs™ provide extensive general functionality including easily selectable pulsing patterns and a full range of basic timing modes (continuous, hi/lo, single cycle, cycle down, etc.).

B-PAC™ Controls



Actionable Diagnostics

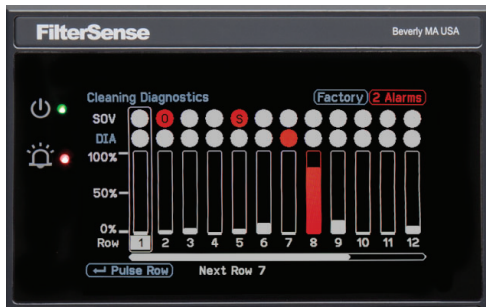

- Locate filter leaks (by row) weeks before visible emissions
- Detect/locate open and shorted solenoids that lead to plugged filters and cascading failures



- Detect and locate ruptured, frozen, and lazy pulse diaphragms
 - One rupture can cost \$1,000/week in compressed air and cause filters to blind
 - Eliminate other problems caused by air loss

EPA, Health & Safety

With integrated particulate monitors and differential pressure sensors, B-PACs™ are best practice for baghouse EPA compliance. They are also ideal for industrial ventilation dust collectors to ensure dust extraction and to help meet OSHA and NFPA regulations.

For safety, B-PACs™ reduce exposure to confined spaces, hazardous pollutants, and emergency maintenance - when most injuries occur.

- Best practice solution for EPA/OSHA/NFPA
- Automate DP control and record keeping
- Fully integrated particulate monitoring
- Eliminate manual inspection of filter mechanicals as required by most permits

Higher Function & Performance than PLCs

Application-specific electronics, combined with diagnostic and control algorithms that have been refined over 10 years, provide performance and capability that cannot be achieved by PLCs. B-PACs™ are turn-key solutions with no need for programming.

A full range of fieldbus options is available to integrate with PLC, DCS, HMI, and SCADA systems. B-PACs™ also offer discrete control modes.

Configurable for All Sizes & Types of Filters

MICS™ platform modularity enables a range of configurations from small cartridge collectors to large multi-compartment baghouses. PRO and basic models offer a wide range of features to suit application and budget needs.

B-PAC™ Series

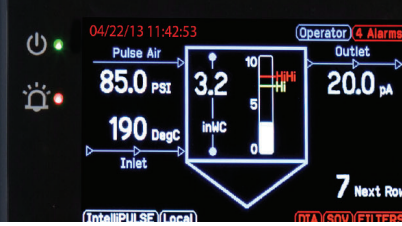

Baghouse Performance Analyzers & Controllers



B-PAC™ G3 PRO

- Top Performance & Heavy-Duty Construction
- Widest Range of Features & Configurations

The B-PAC™ G3 PRO provides a fast return on investment for any baghouse/dust collector. It provides innovative technology for optimum control and EPA/OSHA compliance via its advanced processor/display and the MICS™ platform.



B-PAC™ G3

- Essential Features & Functions
- Lower Price with High Quality

The B-PAC™ G3 provides IntelliPULSE™ pulse-jet DP/cleaning control, particulate monitoring, basic diagnostics, and a solid range of features, functions, and I/O via the MICS™ platform for general improved operation and maintenance planning.

- **Intelligent and Comprehensive DP Control**
 - Easily set/adjust cleaning modes and patterns
- **Integrated DynaCHARGE (ref PM 100 PRO)**
 - All precisions (measure mg/m³, monitor, detect)
- **Real time, Historical and Comparative Trending**
 - For quick set up, understanding, decision making
- **On-Screen Equipment Diagnostics**
 - Instantly view condition of filters, solenoids, valves
- **Device and Process Diagnostics (to NAMUR 107)**
 - Ensure installation and gain time saving insights
- **Alarm Management System**
 - Set logic, groups, acknowledgment, security
- **Data Historian**
 - Extensive data and event recording
- **Choice of Certified Fieldbus, SD card**

Primary I/O

1. Solenoids/Valves
2. DP
3. Particulate
4. Header Pressure

Additional (example)

5. Hopper Level
6. Air Locks
7. Fan Amps
8. Temperature

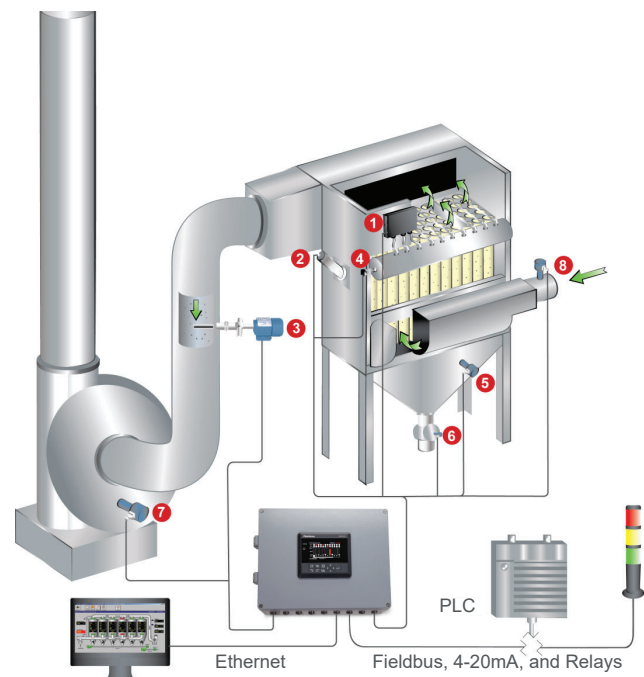

B-PAC™ Model Comparison



Key Features ¹	B-PAC™ G3 PRO	B-PAC™ G3	B-PAC™ PRO ES
Expandable Modular Platform (MICS™)	✓	✓	✓
Distributed Enclosures	✓	Single Enclosure Only	✓
Filter Type	All	Pulse Jet Only	All
Max. # of Compartments	8	2	No Limit
Max. # of Filter Rows	256	96	No Limit
Max # of Header Tanks	8	4	No Limit
IntelliPULSE™ DP Control	✓	✓	✓
Filter Leakage by Row	✓	✓	✓
Solenoid Condition by Row	✓	✓	✓
Diaphragm Condition by Row	✓	✓	✓
On-line Cleaning	✓	✓	✓
Off-line Cleaning			✓
DP Control (flange to flange)	✓	✓	✓
DP Control (by compartment)			✓
On-Screen Trending	✓		✓
Alarm Capabilities	●	◐	●
Data Logging	●	○	●
Device Health Diagnostics	✓		✓
Aux. Monitoring (temperature, flow, level, etc.)	●	○	●
Aux. Control (dampers, screw conveyors, fans, etc.)	◐		●

Application	B-PAC™ G3 PRO	B-PAC™ G3	B-PAC™ PRO ES
Single-Compartment Baghouses	●	◐	●
Mutli-Compartment Baghouses	◐		●
Nuisance Dust Collector(s)	●	●	
EPA Compliance	●	○	●

Technical Data	B-PAC™ G3 PRO	B-PAC™ G3	B-PAC™ PRO ES
Power Supply	100-240 VAC (or) 24 VDC	100-240 VAC (or) 24 VDC	100-240 VAC (or) 24 VDC
Processor/Display	Advanced/Color Graphic	Basic/Monochrome	Advanced/Color Graphic
Analog & Discrete I/O	Up to 16	Up to 4	No Limit
Communication	Fieldbus ²	Fieldbus ²	Fieldbus ²
Ambient Temperature	-40 °F to 158 °F (-40 °C to 70 °C)	-13 °F to 140 °F (-25 °C to 60 °C)	-40 °F to 158 °F (-40 °C to 70 °C)
Enclosure Rating (explosion proof available)	NEMA 4X/IP66	NEMA 4/IP65	NEMA/IP as Requested
Hazardous Area Rating	Class I Div. I (Zone 0/20)	Class II Div. II (Zone 22)	Class I Div. I (Zone 0/20)

Note ²: Certified Fieldbus: EtherNet/IP, Modbus (TCP, RTU), PROFINET IO, PROFIBUS (DPV1, VO), DeviceNet, ControlNet, CanOpen, EtherCAT

Note ¹: Features may be optional

● = Best ◐ = Good ○ = Basic

Pulse-Jet Filter Timers

IntelliPULSE™ pulse-jet timers for baghouses and cartridge dust collectors, compared to basic timer boards, provide intelligent pressure control, energy savings, numerous additional general functions, and higher long-term reliability. For baghouse diagnostics, additional I/O, and advanced features, refer to B-PAC™ controls.



IP 100

- Simple-to-Set Intelligent Filter Cleaning
- Precise Differential Pressure Control (± 0.1 InWC)
- Easily set cleaning parameters, pulsing sequence, and patterns
- Multiple remote discrete control modes or fieldbus
- Full range of basic timing modes (continuous, hi/lo, single cycle, cycle down, etc.)



	IP 100	Traditional Timer Board
Architecture	DIN Modules (MICS™ Platform)	Mostly Bare Circuit Boards
User Interface	Graphic Display & Keypad	Switches or Minimal Display
Dedicated Pulse Outputs	Modular Up to 64 (For Higher, Refer to B-PAC™)	Typically Less Than 32
Pressure Sensor	Modular for Easy Calibration (or Remote Non-Clogging)	Typically Low Quality Fixed to Circuit Board
Fieldbus Communications	Yes (All Major Protocols)	No
Discrete Input Control	Multiple Function	Single Function
Construction	Industrial Duty	Light Duty

Pressure Transmitters

Differential and Static Pressure Transmitters

The DP 20T (differential pressure) and SP 20T (static pressure) transmitters are designed for monitoring filters and any particulate laden process. They prevent the clogging that occurs with gauges and transmitters that use a small tube to the dirty side of the process.

A rugged ceramic sensing element provides accurate measurements in the 0–10 InWC (0-25 mbar) range.



DP 20T & SP 20T

- Non-Clogging, Rugged, and Accurate
- 2-Wire Loop Power, 4-20mA

For differential measurements (DP 20T), the durable ceramic diaphragm is mounted to the dirty side of a process, such as below the tube sheet on a baghouse or on the dirty side of a wet scrubber. The reference port is routed to the clean side. The static version (SP 20T) is for measuring static pressure or vacuum.

A remote control unit is available for local display, PID loop control, relay alarming, and fieldbus communications. The DP 20T and SP 20T are commonly ordered with B-PACs™ and IntelliPULSE™ timers.

- State-of-the-art capacitive sensing element
- 0–10 InWC (0-25 mbar) and higher ranges (also bi-directional ranges)
- Temperature compensation for accurate measurement
- All 316L stainless steel body
- Convenient tri-clamp mounting

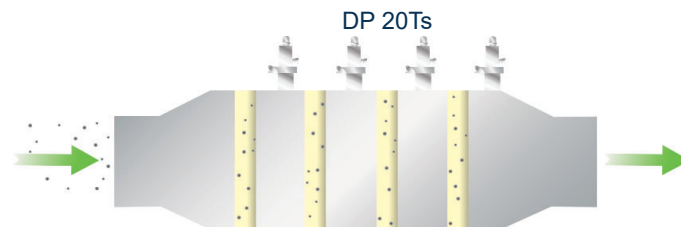
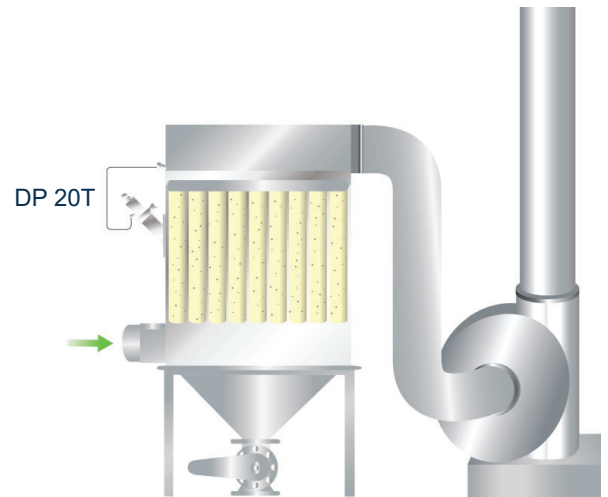

Nearly 60% of maintenance time is spent attempting to diagnose problems.

“With our networked system, we have full control and immediate diagnostics on 123 baghouses” (from central HMI/SCADA).
- Minerals, Plant Engineer



Systems & Software

Engineered B-PAC™ PRO systems, customized HMI/SCADA, and reporting software for central/remote control and management of critical and larger installations.

Solutions:

B-PAC™ PRO ES

FilterWARE™

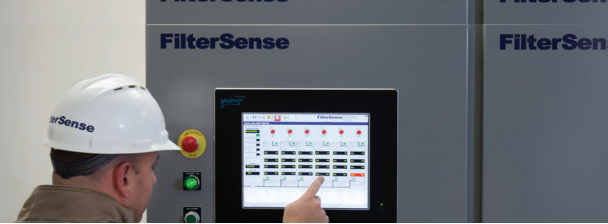

B-PAC™ PRO ES

For a large fabric filter emission source, there is no better solution than a B-PAC™ PRO ES.

The B-PAC™ PRO ES is an engineered system that provides maximum achievable control over particulate emissions to comply with EPA mass emission limits while simultaneously providing process optimization and total filter performance management.

B-PAC™ PRO ES solutions are control and monitoring systems for multi-compartment and large single-compartment baghouses. They integrate B-PAC™ and DynaCHARGE™ technologies with sensing and control engineering for the entire filtration process, control panel design/manufacture, and project management. Controls can include plant specified PLC front ends, HMIs, VFDs, and motor controls. Auburn FilterSense provides full electrical engineering, systems integration, startup, training, and ongoing support.



Features and Benefits:

- **IntelliPULSE™**
 - Extends filter life
 - Minimizes emissions from cleaning
 - Compartment and flange-to-flange DP control
- **Real-time detection and location of failed solenoids and pulse diaphragms**
- **Detect and locate filter leaks early for proactive mass emission compliance assurance**
- **Integrated stack, common outlet, compartment particulate monitoring**
- **Redundancy and control flexibility from B-PAC™ “compartment controllers”**
- **Integrated compressed air management**
- **On-line and off-line cleaning modes**
- **Highly configurable cleaning parameters, row sequencing, and patterned pulsing**
- **Integrated safety overrides and maintenance modes with local and PLC control**
- **HMI/SCADA, record keeping, reporting, and remote access via FilterWARE™**



FilterWARE™ HMI/SCADA & Reporting Software

The **Standard Edition** is reliable and secure HMI/SCADA software for remote/central monitoring, analysis, and control. It provides interface to B-PAC™ controls and DynaCHARGE™ particulate monitors, SQL data historian, optional email notifications, and report generation. Reports can include maintenance, process, and EPA reports for specific regulations. Remote access enables remotesupport from Auburn FilterSense and access between plant and central office. The **Process Edition** is a simplified (HMI only) version for B-PAC PRO ES user interface.

FilterWARE™ automates process control, maintenance, and EPA compliance needs simultaneously providing time-saving convenience and a fast return on investment.

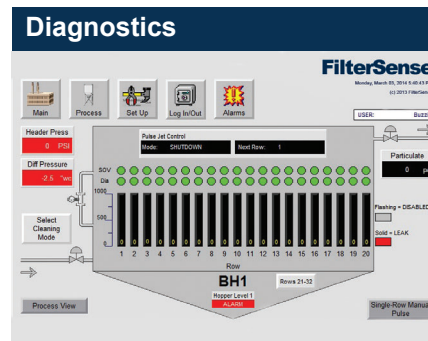
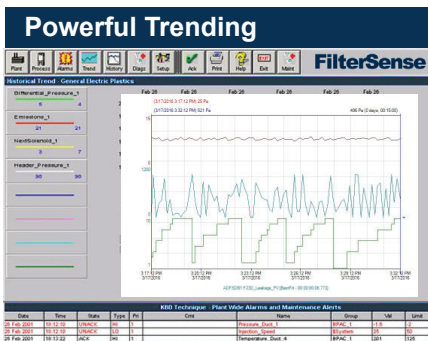
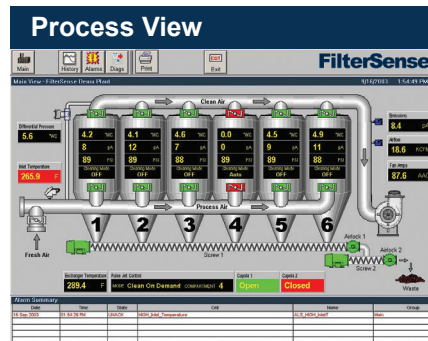
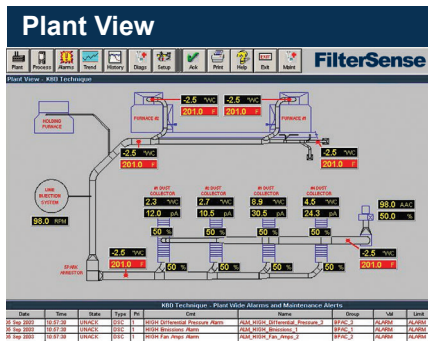

Reporting

- Automated EPA compliance reports
- Process and maintenance reports
- Custom or standard formats

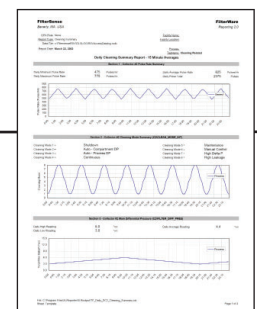
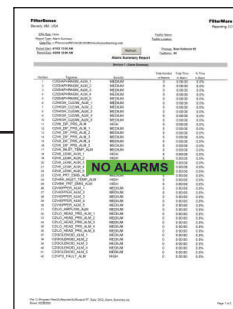
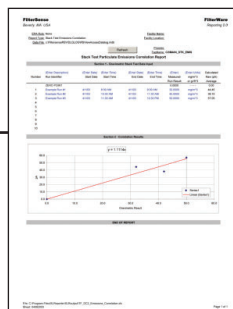

Experienced end-users and leading OEMs trust Auburn FilterSense to prevent excess emissions, maintain compliance, and improve operations.

Our Edge in technology, quality, and support is **Your Advantage** and what makes Auburn FilterSense the #1 choice for reliable solutions.

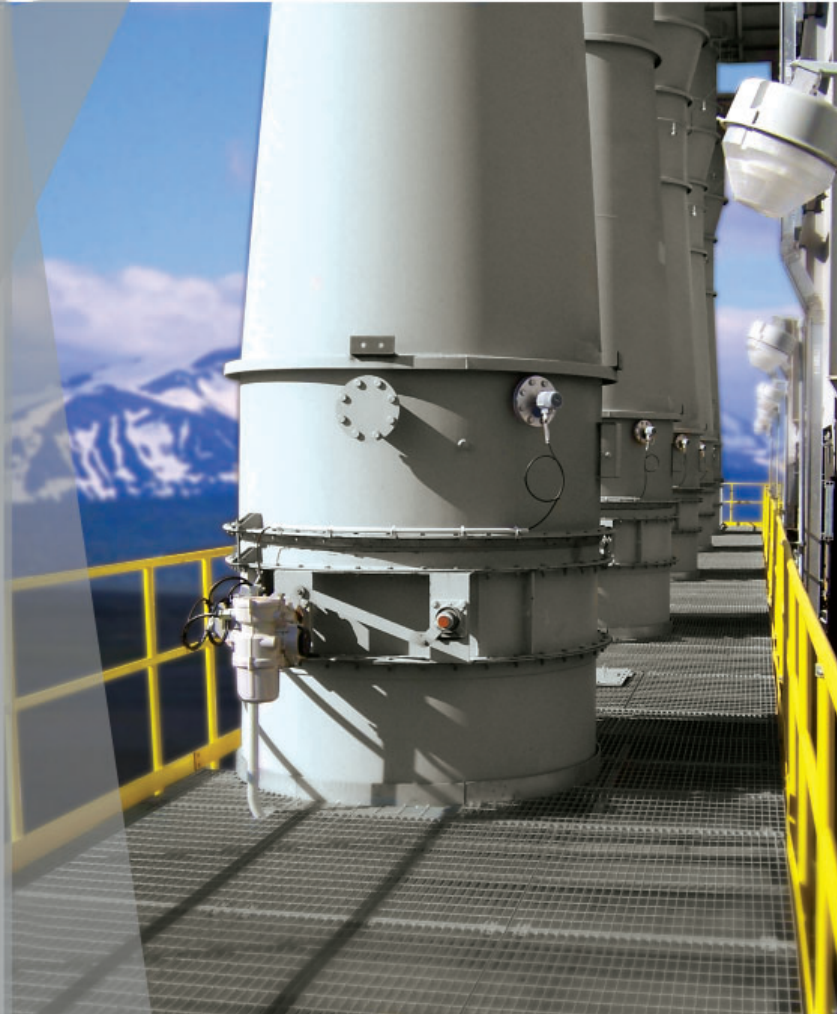

Auburn FilterSense

Particulate Measurement and Control Solutions

800 Cummings Center, 355W
Beverly, MA 01915 USA
Tel: 978-927-4304
Fax: 978-927-4329
www.FilterSense.com

Made in the USA

Our Edge Is Your Advantage

"We trust that when one of our four Auburn FilterSense monitors is in alarm, it's due to a leaking filter." - Cement, Environmental Manager

"PM 100 is our main filter analyzer. It would not be possible to detect small leaks without it." - Aluminum, Plant Engineer

"The tribo units were always false alarming from moisture during startup, delaying production." - Pharmaceutical, Dryer Operator

"DynaCHARGE™ is like a microscope; we see things we never saw with our opacity monitor. And we don't have to clean it!" - Lead Battery, Plant Manager

"The leak was exactly where the B-PAC™ indicated it was; we were only shutdown for minutes." - Chemical, Plant Engineer