

# Pharmaceutical

*Enhancing Fluid Bed Dryer performance with PM 1 PRO Particulate Sensors*

Elevating Equipment Performance and Repeatable Process Integrity

## Challenge

When looking at the highly regulated and quality-driven pharmaceutical industry, fluid bed dryers play a critical role in processing bulk solids, including drying powder products and spray coating fine particulates. This application note will take a look at an OEM partner, a globally recognized leader who stands out for their superior quality, durability, and precision. To further enhance their value proposition and solidify their competitive edge, they have integrated Auburn PM 1 PRO Particulate Sensors for filter leak detection into their systems.

### Maximized Yield, Safety, and Compliance

Pharmaceutical powder batches can be valued at over one million dollars, making every percentage of yield retention crucial to profitability. Additionally, with increasingly potent pharmaceuticals, maintaining a safe working environment and preventing emissions that could impact employees and the surrounding community are paramount. Without effective filter leak detection, even minor failures can lead to significant product loss, environmental hazards, and costly production downtime.

### How the Technology Works

Fluid bed dryers operate by blowing air through powder to dry and spray coat it, a process that demands precise control and repeatability. Auburn's particulate sensors monitor critical points within the system where powder attrition and filter wear are most likely to occur. The data provided allows for proactive interventions to deliver consistent performance and avoid catastrophic failures.

## Solution

By integrating Auburn's PM 1 PRO Sensors into their fluid bed dryers, the featured OEM offers their customers a proactive solution to—

**Minimize Product Loss:** Continuous monitoring of filter performance provides immediate leak detection, allowing operators to take swift corrective actions before valuable product is lost.

**Enhance Safety:** Monitoring dust levels before and after HEPA filters provides a failsafe against exposure to toxic or hazardous particulates, safeguarding employees, neighbors, and the environment.

**Optimize Maintenance Planning:** Predictive maintenance strategies enabled by PM 1PRO Particulate sensors help to minimize unplanned downtime and extend the lifespan of critical filter components.

**Support Regulatory Compliance:** With stringent pharmaceutical regulations, maintaining air quality and product integrity is crucial. Auburn's charge induction technology provides confidence in meeting compliance standards.



## Conclusion

### Competitive Differentiation through Reliability

Our OEM partner is renowned for producing fluid bed dryers with exceptional air movement precision and repeatability. By integrating Auburn's PM 1 PRO Particulate Sensors, they deliver added value to their customers through:

- **Increased Yield:** Reliable detection minimizes waste and ensures higher production efficiency.
- **Process Reliability:** Customers gain confidence in maintaining consistent production outcomes with validated air quality monitoring.
- **Environmental Responsibility:** Proactively preventing emissions helps customers uphold their commitment to environmental stewardship and community safety.
- **Market Leadership:** Offering advanced monitoring capabilities further reinforces the OEM's reputation for delivering the best-in-class solutions.

By incorporating PM 1 PRO Particulate Sensors, our OEM partner is not only enhancing the value of their fluid bed dryers but also empowering their customers to operate at peak efficiency with confidence. From protecting high-value pharmaceutical products to supporting compliance and safety, the addition of advanced filter leak detection transforms their equipment into an indispensable asset in pharmaceutical manufacturing.



## Featured Products

### PM 1 PRO – Particulate Monitoring



The PM 1 PRO is a state-of-the-art particulate monitor designed for pharmaceutical processes, using induction-sensing charge technology for accurate detection of particulate leaks. It prevents product loss and ensures workplace safety by providing early warnings of filter failures, even in challenging conditions with damp or sticky dust.

### WorkSpace – Ambient Air Monitoring



Provides real-time monitoring of workplace air quality by detecting fugitive dust, including hazardous varieties. In the pharmaceutical industry, it enhances employee safety and supports compliance with strict regulations by identifying dust leaks or process upsets before they pose health or product risks.

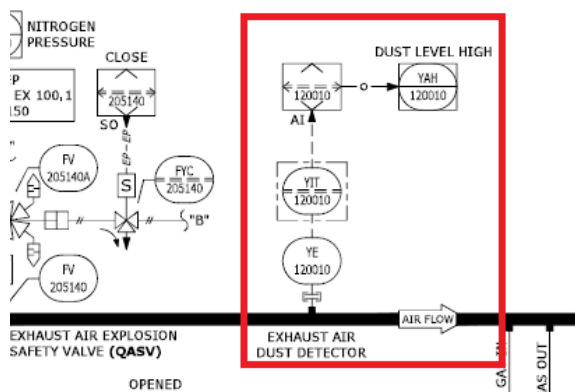

The Exhaust Air Dust Detector monitors industrial dust levels, triggering alerts when they're too high to support clean air, efficiency, and compliance.



Scan To  
**Learn More**

Contact Us Today

sales@auburnfs.com | +1 978.927.4304

www.auburnfs.com